



Monolithic CMOS Analog Multiplexers

DG506A/DG507A

General Description

Maxim's DG506A and DG507A are monolithic CMOS analog multiplexers. The DG506A is a single 16 channel (1 of 16) multiplexer, and the DG507A is a differential 8 channel (2 of 16) multiplexer.

Both devices feature break-before-make switching. Maxim guarantees that these multiplexers will not latch-up if the power supplies are turned off with the input signals still present as long as absolute maximum ratings are not violated. The multiplexers operate over a wide range of power supplies from $\pm 4.5V$ to $\pm 18V$.

Compared to the original manufacturer's devices, Maxim's DG506A and DG507A consume significantly less power, making them ideal for portable equipment.

Maxim's DG506A and DG507A meet or exceed the specifications of, and are drop-in replacements for, Intersil's IH6116 and IH6216, Siliconix's DG506A and DG507A, and Harris' HI506 and HI507.

Applications

- Control Systems
- Data Logging Systems
- Aircraft Heads Up Displays
- Data Acquisition Systems
- Signal Routing

Typical Operating Circuit

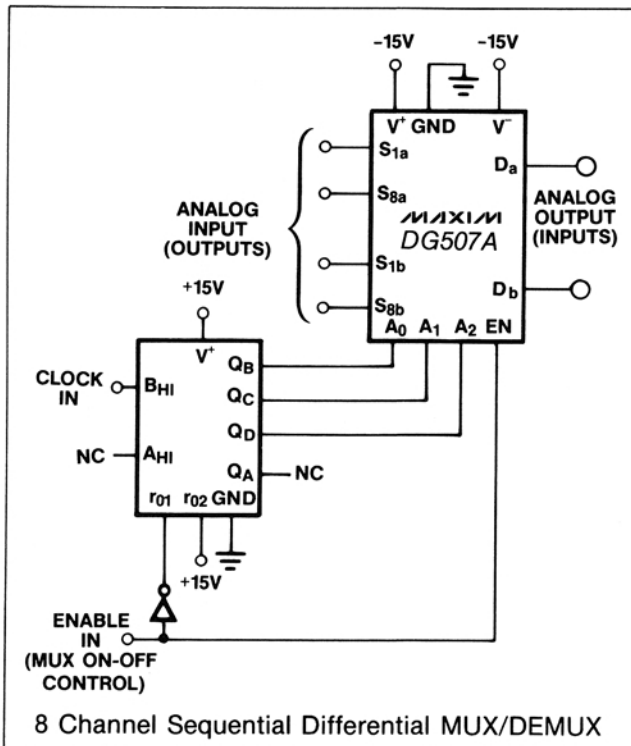

Features

- ◆ Improved 2nd Source!
- ◆ Pin compatible with Harris, Siliconix, Intersil
- ◆ Operable with $\pm 4.5V$ to $\pm 18V$ Supplies
- ◆ Symmetrical, Bi-Directional Operation
- ◆ Logic and Enable inputs, TTL and CMOS Compatible
- ◆ Latch-Up Proof Construction
- ◆ Monolithic, Low-Power CMOS Design

Ordering Information

PART	TEMP RANGE	PACKAGE
DG506AAK	-55°C to +125°C	28 Lead CERDIP
DG506ABK	-20°C to +85°C	28 Lead CERDIP
DG506AC/D	0°C to +70°C	Dice
DG506ACJ	0°C to +70°C	28 Lead Plastic DIP
DG506ACK	0°C to +70°C	28 Lead CERDIP
DG506ACWI	0°C to +70°C	28 Lead Wide SO
DG507AAK	-55°C to +125°C	28 Lead CERDIP
DG507ABK	-20°C to +85°C	28 Lead CERDIP
DG507AC/D	0°C to +70°C	Dice
DG507ACJ	0°C to +70°C	28 Lead Plastic DIP
DG507ACK	0°C to +70°C	28 Lead CERDIP
DG507ACWI	0°C to +70°C	28 Lead Wide SO

Pin Configurations

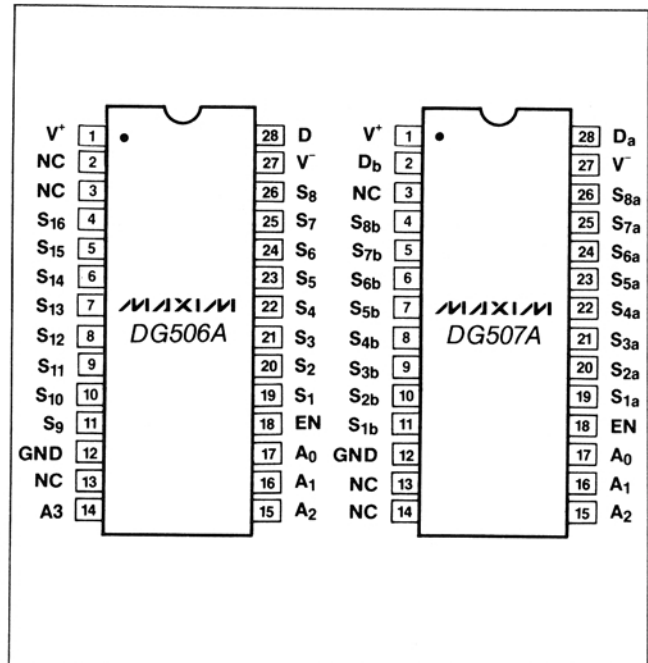

Monolithic CMOS Analog Multiplexers

ABSOLUTE MAXIMUM RATINGS

Voltage Referenced to V⁻

V ⁺	44V
GND	25V
Digital Inputs V _s , V _D (Note 1)	-2V to (V ⁺ + 2V) or 20mA, whichever occurs first.
Current, Any Terminal Except S or D	30mA
Continuous Current, S or D	20mA
Peak Current, S or D (Pulsed at 1msec, 10% duty cycle max)	40mA
Storage Temperature (A & B Suffix)	-65°C to 150°C
(C Suffix)	-65°C to 125°C

Operating Temperature (A Suffix)	-55°C to 125°C
(B Suffix)	-25°C to 85°C
(C Suffix)	0°C to 70°C

Power Dissipation (Package)*	
28 Pin Ceramic DIP**	1200mW
28 Pin Plastic DIP***	625mW

*All leads soldered or welded to PC board.

**Derate 16mW/°C above 75°C

***Derate 8.3mW/°C above 75°C

Stresses listed under "Absolute Maximum Ratings" may be applied (one at a time) to devices without resulting in permanent damage. These are stress ratings only, and functional operation of the device at these or any other conditions above those indicated in the operational sections of the specifications is not implied. Exposure to absolute maximum ratings conditions for extended periods may affect device reliability.

ELECTRICAL CHARACTERISTICS (V⁺ = 15V, V⁻ = -15V, GND = 0V, T_A = 25°C, unless otherwise indicated.)

PARAMETER	SYMBOL	TEST CONDITIONS	DG506AA DG507AA			DG506AB/C DG507AB/C			UNITS	
			MIN	TYP	MAX	MIN	TYP	MAX		
SWITCH										
Analog Signal Range	V _{ANALOG}		-15		15	-15		15	V	
Drain-Source ON Resistance	r _{DS(on)}	Sequence Each Switch On V _{AL} = 0.8V, V _{AH} = 2.4V, V _{EN} = 2.4V	V _D = 10V, I _S = -200μA		270	400	270 450		Ω	
			V _D = -10V, I _S = -200μA		230	400	230 450			
Greatest Change in Drain-Source ON Resistance Between Channels	Δr _{DS(on)}	$\Delta r_{DS(on)} = \left(\frac{r_{DS(on)}^{MAX} - r_{DS(on)}^{MIN}}{r_{DS(on)}^{AVE}} \right)$ -10V ≤ V _S ≤ 10V			6		6		%	
Source OFF Leakage Current	I _{S(off)}	V _{EN} = 0.8V V _{AL} = 0.8V	V _S = 10V, V _D = -10V	-1	0.002	1	-5	0.002	5	nA
Drain OFF Leakage Current	I _{D(off)}		V _S = -10V, V _D = 10V	-1	-0.005	1	-5	-0.005	5	
			V _D = 10V, V _S = -10V	-10	0.02	10	-20	0.02	20	
			V _D = -10V, V _S = 10V	-10	-0.03	10	-20	-0.03	20	
			V _D = 10V, V _S = -10V	-5	0.007	5	-10	0.007	10	
		V _D = -10V, V _S = 10V	-5	-0.015	5	-10	-0.015	10		
Channel ON Leakage Current	I _{D(on)} ⁴	Sequence Each Switch On V _{AL} = 0.8V, V _{AH} = 2.4V, V _{EN} = 2.4V	V _{S(all)} = V _D = 10V	-10	0.03	10	-20	0.03	20	
			V _{S(all)} = V _D = -10V	-10	-0.06	10	-20	-0.06	20	
			V _{S(all)} = V _D = 10V	-5	0.015	5	-10	0.015	10	
			V _{S(all)} = V _D = -10V	-5	-0.03	5	-10	-0.03	10	
INPUT										
Address Input Current, Input Voltage High	I _{AH}	V _A = 2.4V	-10	-0.002		-10	-0.002		μA	
		V _A = 15V		0.006	10		0.006	10		
Address Input Current, Input Voltage Low	I _{AL}	All V _A = 0	V _{EN} = 2.4V	-10	-0.002		-10	-0.002	μA	
			V _{EN} = 0	-10	-0.002		-10	-0.002		

Monolithic CMOS Analog Multiplexers

DG506A/DG507A

ELECTRICAL CHARACTERISTICS (Continued)

(V^+ = 15V, V^- = -15V, GND = 0V, T_A = 25°C, unless otherwise indicated.)

PARAMETER	SYMBOL	TEST CONDITIONS	DG506AA DG507AA			DG506AB/C DG507AB/C			UNITS
			MIN (Note 2)	TYP (Note 3)	MAX	MIN (Note 2)	TYP (Note 3)	MAX	
DYNAMIC									
Switching Time Of Multiplexer	$t_{\text{transition}}$	See Figure 1	0.6	1		0.6			μs
Break-Before-Make Interval	t_{open}	See Figure 3	0.2			0.2			
Enable Turn-ON Time	$t_{\text{on(EN)}}$	See Figure 2	1			1			
Enable Turn-OFF Time	$t_{\text{off(EN)}}$		0.4			0.4			
OFF Isolation ²	OIRR	$V_{\text{EN}} = 0, R_L = 1\text{k}\Omega, C_L = 15\text{pF}$ $V_S = 7V_{\text{rms}}, f = 500\text{kHz}$	68			68			dB
Source OFF Capacitance	$C_{\text{S(off)}}$	$V_{\text{EN}} = 0,$ $f = 140\text{kHz}$	$V_S = 0$		6	$V_D = 0$		6	pF
Drain OFF Capacitance	DG506A		$V_D = 0$		45	$V_D = 0$		45	
	DG507A		$V_D = 0$		23	$V_D = 0$		23	
SUPPLY									
Positive Supply Current	I^+	$V_{\text{EN}} = 0\text{V or } 5\text{V, All } V_A = 0$.13	.25		.13	.3		mA
Negative Supply Current	I^-		-0.15	-0.07		-0.25	-0.07		

Note 1: Signals on S_x , D_x , or IN_x exceeding V^+ or V^- will be clamped by internal diodes. Limit forward diode current to maximum current ratings.

Note 2: The algebraic convention whereby the most negative value is a minimum, and the most positive value is a maximum, is used in this data sheet.

Note 3: Typical values are for DESIGN AID ONLY, not guaranteed nor subject to production testing.

Note 4: $I_{\text{D(on)}}$ is leakage from driver into "ON" switch.

Note 5: OFF isolation = $20 \log \frac{V_D}{V_S}$, V_S = input to "OFF" switch, V_D = output due to V_S .

Monolithic CMOS Analog Multiplexers

ELECTRICAL CHARACTERISTICS (Over Temperature)

($V^+ = 15V$, $V^- = -15V$, GND = 0V, T_A = Over Temperature Range, unless otherwise indicated.)

PARAMETER	SYMBOL	TEST CONDITIONS	DG506AA DG507AA			DG506AB/C DG507AB/C			UNITS
			MIN	TYP	MAX	MIN	TYP	MAX	
SWITCH									
Analog Signal Range	V_{ANALOG}		-15		15	-15		15	V
Drain-Source ON Resistance	$r_{DS(on)}$	Sequence Each Switch On $V_{AL} = 0.8V$, $V_{AH} = 2.4V$, $V_{EN} = 2.4V$	$V_D = 10V$, $I_S = -200\mu A$		500			550	Ω
			$V_D = -10V$, $I_S = -200\mu A$		500			550	
Source OFF Leakage Current	$I_{S(off)}$		$V_S = 10V$, $V_D = -10V$	-50	50	-50	50	nA	
Drain OFF Leakage Current	DG506A	$V_{EN} = 0.8V$ $V_{AL} = 0.8V$	$V_D = 10V$, $V_S = -10V$	-300	300	-300	300		
			$V_D = -10V$, $V_S = 10V$	-300	300	-300	300		
	DG507A		$V_D = 10V$, $V_S = -10V$	-200	200	-200	200		
			$V_D = -10V$, $V_S = 10V$	-200	200	-200	200		
Channel ON Leakage Current	DG506A	Sequence Each Switch On $V_{AL} = 0.8V$, $V_{AH} = 2.4V$, $V_{EN} = 2.4V$	$V_{S(ALL)} = V_D = 10V$	-300	300	-300	300		
			$V_{S(ALL)} = V_D = -10V$	-300	300	-300	300		
	DG507A		$V_{S(ALL)} = V_D = 10V$	-200	200	-200	200		
			$V_{S(ALL)} = V_D = -10V$	-200	200	-200	200		
INPUT									
Address Input Current, Input Voltage High	I_{AH}	$V_A = 2.4V$	-30		-30			μA	
		$V_A = 15V$		30		30			
Address Input Current, Input Voltage Low	I_{AL}	All $V_A = 0$	$V_{EN} = 2.4V$	-30		-30			
			$V_{EN} = 0$		30		30		

Note 1: Signals on S_x , D_x , or IN_x exceeding V^+ or V^- will be clamped by internal diodes. Limit forward diode current to maximum current ratings.

Note 2: The algebraic convention whereby the most negative value is a minimum, and the most positive value is a maximum, is used in this data sheet.

Note 3: Typical values are for DESIGN AID ONLY, not guaranteed nor subject to production testing.

Note 4: $I_{D(on)}$ is leakage from driver into "ON" switch.

Note 5: OFF isolation = $20 \log \frac{V_D}{V_S}$, V_S = input to "OFF" switch, V_D = output due to V_S .

Monolithic CMOS Analog Multiplexers

DG506A/DG507A

Truth Tables

DG506A

A ₃	A ₂	A ₁	A ₀	EN	ON SWITCH
X	X	X	X	0	NONE
0	0	0	0	1	1
0	0	0	1	1	2
0	0	1	0	1	3
0	0	1	1	1	4
0	1	0	0	1	5
0	1	0	1	1	6
0	1	1	0	1	7
0	1	1	1	1	8
1	0	0	0	1	9
1	0	0	1	1	10
1	0	1	0	1	11
1	0	1	1	1	12
1	1	0	0	1	13
1	1	0	1	1	14
1	1	1	0	1	15
1	1	1	1	1	16

DG507A

A ₂	A ₁	A ₀	EN	ON SWITCH
X	X	X	0	NONE
0	0	0	1	1
0	0	1	1	2
0	1	0	1	3
0	1	1	1	4
1	0	0	1	5
1	0	1	1	6
1	1	0	1	7
1	1	1	1	8

Logic "0" = $V_{AL} \leq 0.8V$, Logic "1" = $V_{AH} \geq 2.4V$
 "0" = DON'T CARE

Switching Time Test Circuit

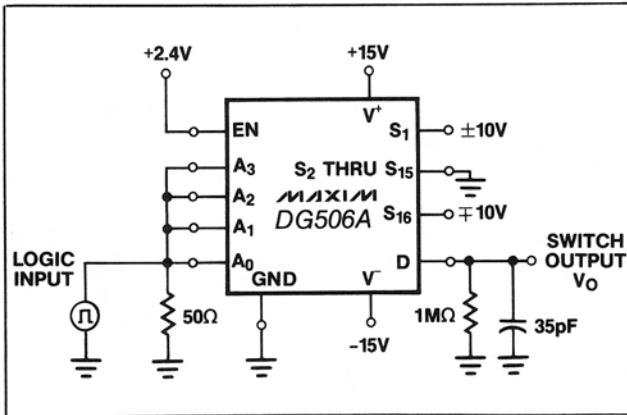

Figure 1A. Transition Switching Time

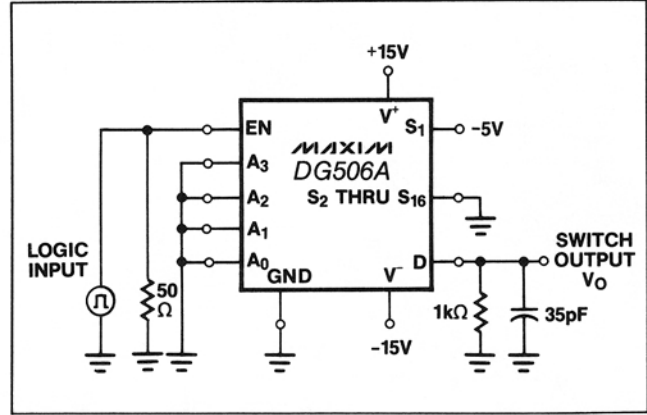

Figure 2A. Enable Switching Time

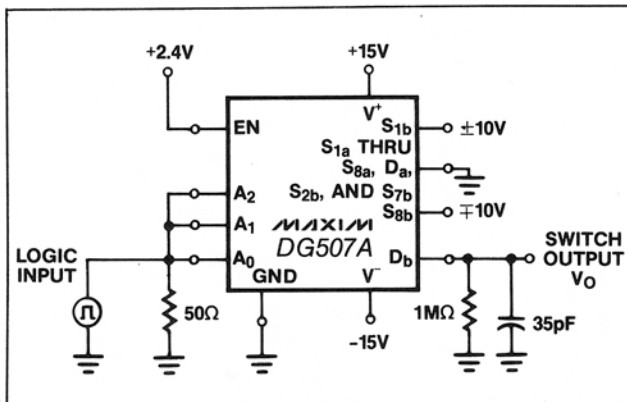

Figure 1B. Transition Switching Time

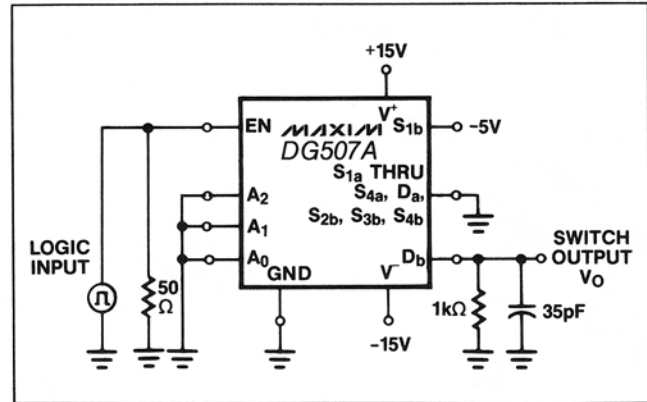

Figure 2B. Enable Switching Time

Monolithic CMOS Analog Multiplexers

Switching Time Test Circuit (continued)

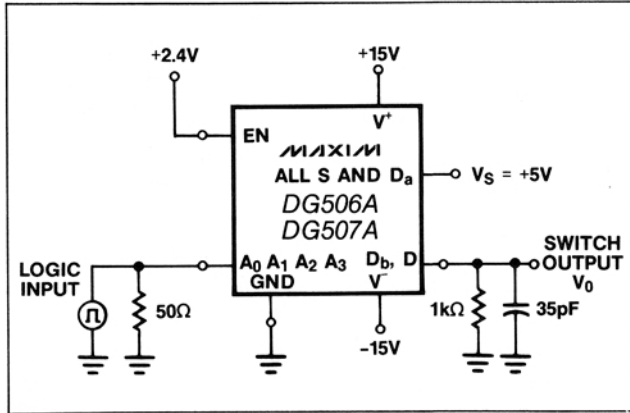

Figure 3. Break-Before-Make

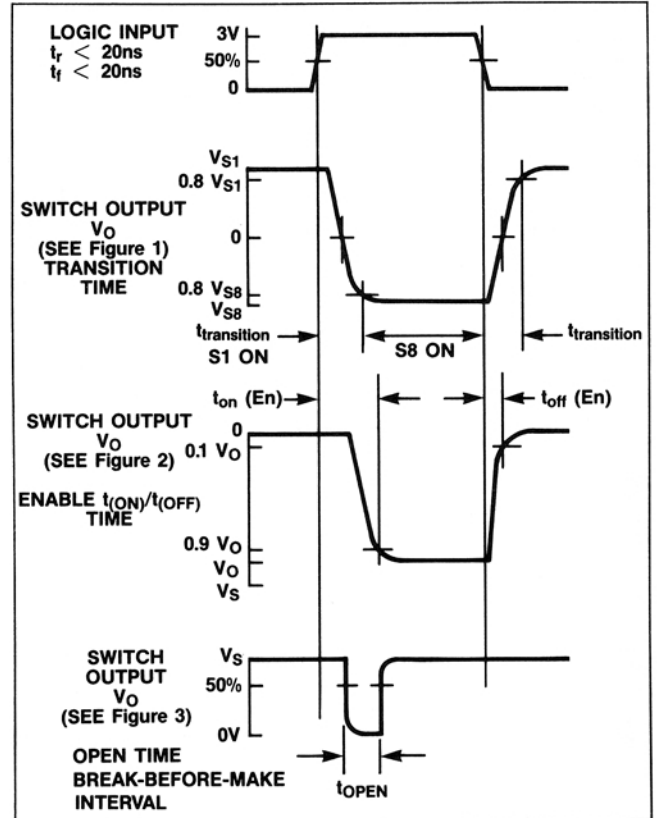
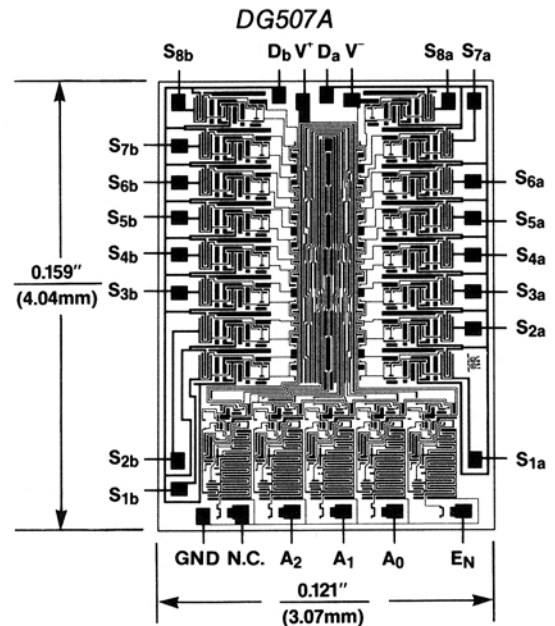
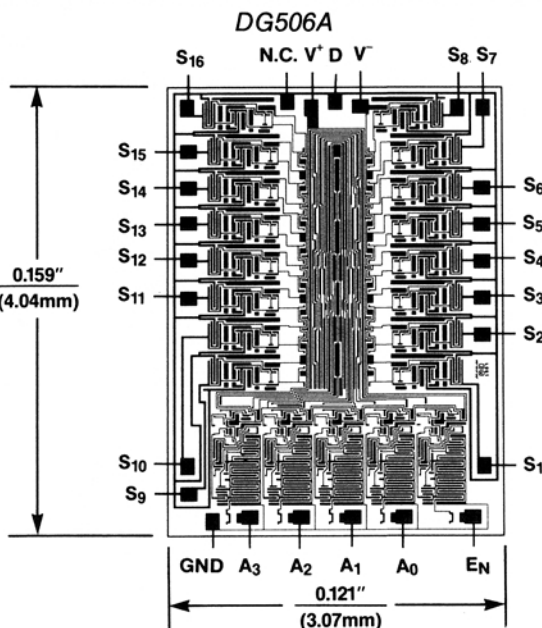

Figure 4. Timing Diagrams for Figures 1, 2, and 3

Chip Topography



Maxim cannot assume responsibility for use of any circuitry other than circuitry entirely embodied in a Maxim product. No circuit patent licenses are implied. Maxim reserves the right to change the circuitry and specifications without notice at any time.